

ARTOS High-quality, powerful wet / dry vacuum cleaner at a fair price.



TECHNICAL DATA

Voltage	230 V / 50 Hz
Max. power	1200 W
Sound pressure level	76 dB(A)
Volume flow rate	48 litres / sec.
Max. suction	230 mbar
Container material	stainless steel
Container volume	30 litres (gross)
Length of power cable	7,5 m
Length of hose	2,5 m
Diameter of hose	32 mm
Diameter of tubes	32 mm
Weight	8,9 kg
Dimensions (L x W x H)	42 x 38 x 63 cm



Wet floor nozzle 360 mm
Item no. 101.087

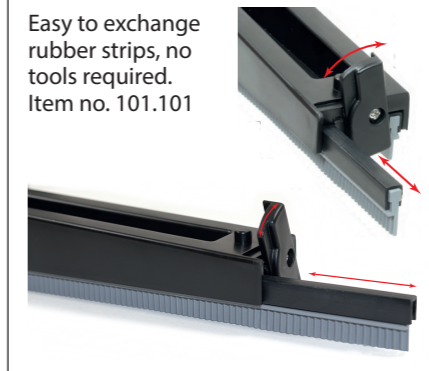

Easy to exchange rubber strips, no tools required.
Item no. 101.101



Always close to the action: 4 accessory slots and a park position for attachments on the back of the vacuum.



Easy hose click system.

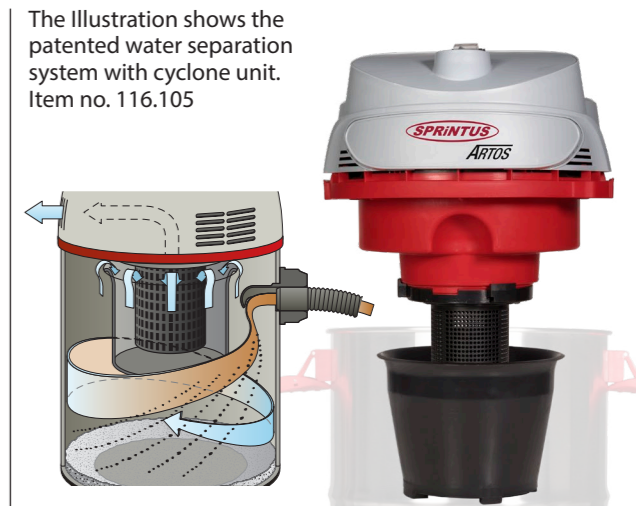

The illustration shows the patented water separation system with cyclone unit. Item no. 116.105

Due to the twist of the intake nozzle, the spray-fog is consequently diverted along the inner container wall. Additional filters are no longer necessary. The reliable floater system even reacts during heavy foam growth. Cooling air slots located on the side ensure the consistent separation of cooling and processed air.



Cyclone unit
Item No. 116.105



HEPA 13 fine dust filter cartridge
Item no. 116.106



Suggested Use

The vacuum cleaner is perfect for cleaning buildings, industrial facilities and workshops due to its power, compact size and robust design.

The newest SPRINTUS highlight, wet / dry vacuum cleaner Artos in the 30-litre class, impresses thanks to its high quality and sensational value for money. Innovative features, such as the cyclone water separation system with a reliable floater system, sets the Artos clearly apart from the other wet / dry vacuum cleaner models in the entry-level class. The wide chassis and long wheelbase make the Artos a particularly agile machine, which can be manoeuvred easily over

the surface to be cleaned. The 360 mm wide floor nozzle included in the basic configuration is extremely user-friendly and can be converted from a wet floor nozzle to a dry floor nozzle by simply exchanging the rubber strips for brush strips. High-quality components, such as the strong stainless-steel container and the 1200 Watt motor, make the Artos a robust and reliable partner in professional cleaning.



The blower function is integrated on the top of the appliance and is activated simply by attaching the vacuum hose.

	Item no.
ARTOS	116.001
2 x 0,5 m aluminium tube ø 32 mm, 2,5 m suction hose, crevice nozzle, furniture nozzle, wet floor nozzle 360 mm, brush strip set 360 mm, HEPA 13 fine dust filter cartridge, cyclone unit, fleece filter bag, 7,5 m power cable, black	
STANDARD KIT:	
Aluminium tube, 0,5 m (1 piece)	106.026
2,5 m suction hose complete	114.113
Wet floor nozzle 360 mm	101.106
Brush strip set 360 mm	101.100
Crevice nozzle	101.023
Furniture nozzle	101.024
Cyclone unit	116.105
HEPA 13 fine dust filter cartridge	116.106
7,5 m power cable, black	101.074
ACCESSORIES:	
Fleece filter bags (5 pieces)	101.020
Parquet nozzle 360 mm	111.202
Crevice nozzle flexible 600 mm	111.203
Telescopic tube, stainless steel, 0,6 - 1,0 m	111.133
Spare lip 101.106	101.101